



Company Specific Addendum

July 2009

(Revised 24/07/09)

**to Code of Practice for the Self-Laying
of Water Mains and Services**

– England and Wales

3rd Edition

Foreword

This **Southern Water Company Specific Addendum** is provided, in accordance with the UKWIR/SBWWI/Water UK publication “**Self Laying of Water Mains and Services – A Code of Practice for England and Wales – 2nd Edition**” and the OFWAT publication “Guidance on financial arrangements for self-lay and requisitioning agreements.”

The Addendum supplements the Code of Practice on specific areas to align with Southern Water’s own practices and procedures.

Due to the number of references within this Addendum to items that Southern Water will from time to time need to amend in line with regular reviewing procedures and natural evolutionary changes, you should ensure that you are always working with the current version of this document. The current version is available as a download from Southern Water’s website “www.southernwater.co.uk” http://www.southernwater.co.uk/pdf/businessCustomers/devAndHousebuilders/PNM1294_CSA_v2.pdf at all times, however, as a general guide, this document will always be amended at the start of any new financial year, to accommodate changes to Southern Water’s standard charges.

If you have reason to dispute any aspect of Southern Water’s approach to Self-Lay, please raise the issue with us in the first instance. However, if you consider that we have not resolved the issue to your satisfaction you can refer the matter to OFWAT for resolution, at www.ofwat.gov.uk

PART 1	GENERAL	
1.5	Competency of Self Lay Organisations	
1.5.4		a) The Developer/SLO shall provide evidence to demonstrate the competence of any proposed operatives not suitably approved under the Water Industry Registration Scheme (WIRS) to Southern Water for prior approval. b) Southern Water may require to undertake ongoing audits of competence. c) Completion of form SL2 provided in Appendix A to this Addendum.
1.6	Protection of Water Quality	
1.6.3		a) The Developer/SLO shall comply with Southern Water’s Hygiene Code of Practice included in Appendix A to this addendum.
1.6.7 and 1.6.8		a) Timescales and procedures for sampling, commissioning, flushing and re-sampling shall be in accordance with Southern Water’s Disinfection & Hygiene Procedures For New Water Mains And Services (WM-D 326) included in Appendix B to this addendum and subject to agreement and arrangement on a case by case basis with Southern Water. Typical details of Temporary Spade and Bypass Arrangements (WM-D 424 and 425) are included in Appendix C to this document.
1.6.9		a) Southern Water will issue a Water Regulations Application form https://www.southernwater.co.uk/pdf/businessCustomers/waterRegs/PNM2406_NotificationForm.pdf for each new application. Upon receipt of each completed form, Southern Water will grant consent

		for connection if satisfied that the installation meets the required standards. As part of this Southern Water will need to carry out a physical inspection of the new service pipe and installation prior to backfilling of the associated pipe trench.
1.11	Finances	A schedule of Southern Water's Standard Charges is included in Appendix D to this Addendum.
1.15.4	Standards	The Developer/SLO shall submit a schedule of products and substances proposed to be used for the works to Southern Water for prior approval. To aid efficiency of the approval process these should be listed on form SL3 contained in Appendix E to this addendum, along with associated supporting information.
1.15.5		Southern Water has developed a list of Standard Assets used for its own works, current details of which are available on request.
PART 2	SELF-LAY PROCEDURES	
2.2 Figure 4	Initial Enquiry	Please note that although Figure 4 is headed "Initial Enquiry Procedure", the applicable Los 2a is deemed to apply at the stage the Developer has started the formal application process and is seeking to obtain final estimates of prices for the self-lay (or requisition) process; i.e. it refers to the detailed information required by a SLO to proceed with a final design and not for a preliminary enquiry to understand the indicative cost and extent of network reinforcement.

2.4.2.4	Water Main Installation	<p>a) Southern Water shall witness all pressure tests and the disinfection of all or some mains. Accordingly the Developer/SLO shall coordinate and programme swabbing, testing and disinfection operations by liaison and prior agreement with Southern Water. Unless specifically agreed otherwise, Southern Water will accept three types of pressure test as standard practice as follows, and all testing operations shall be clearly identified on site using appropriate notice boards:</p> <ul style="list-style-type: none"> ▪ Test 1, Visual Test - Suitable only where continuous coils of HPPE pipe are installed in either 50 metre, 75 metre or 100 metre coils. Mains will be filled to standing head pressure of existing mains at the point of contact between dead & live systems ▪ Type 1 Test - A Type 1 test will be allowed for schemes where the installation is no greater in length than 200 metres and the pipe OD does not exceed 180mm. All Testing will be recorded by use of loggers only and will be completed by swabbing the line and raising the internal pressure to match the Standing Head pressure of the mains at point of contact between dead and live systems. Once the new line has been filled, the newly charged mains will be left for 24 hours to achieve creep and stress relaxations. The internal pressure must then be raised to 1.5 times the Standing Head pressure then progress monitored by viewing the logger. Once the test pressure has been achieved, the internal test pressures can be reduced to 2 Bar standing head level. Continued monitoring via the pressure loggers will indicate a rise in internal pressures over a set time line of approximately 1 hour. Copies of the pressure test graph must be attached to the pressure test completion certificate and presented to Southern Water's representative. ▪ Wrc Type 2 Test - The Wrc Test will be undertaken for all works other than those tests which are deemed Visual or Type 1. All Testing will be recorded by use of loggers only and be completed by swabbing the line and raising the internal pressure to match the Standing Head pressure of the mains at point of contact between Dead & Live systems. Once the new line has been filled, the newly charged mains will be left for 24 hours to achieve creep and stress relaxations. Wrc Testing requires a disciplined approach and follows a set timeframe. Copies of the pressure test graph must be attached to the pressure test completion certificate and presented to Southern Water's representative.
2.4.3	Final Connection	a) Southern Water will generally permit the Developer/SLO routine inline

		final connections between a new section of live main previously laid by the Developer/SLO and a continuing section of new main (Main Under Construction) being laid by the same Developer/SLO subject to the connection being carried out in accordance with Southern Water's procedures as detailed in Appendix B to this addendum and until satisfactory disinfection, pressure test and water sample results have been provided to Southern Water. b) Southern Water requires to witness connections described in a) above and as such the SLO/Developer shall not undertake such connections without prior arrangement and Southern Water attendance on site. c) The Developer/SLO shall install a DSV (double spade valve) wherever there is a temporary termination of a water main for planned further extension.
2.4.4.3	Service Pipe Installation	See 1.6.9 above
PART 3	DESIGN AND CONSTRUCTION GUIDANCE	
3.5.2	Depth of Cover	a) Mains shall be laid to provide a minimum cover of 750mm above the crown of the pipe.
3.5.3.3	Sizing of Mains	(a) Details of current pressure and flow at the site boundary will be provided on request subject to payment of the relevant charge for provision of this data. However, the Develop/SLO should take into consideration that these pressures and flows are subject to future change, and that the regulatory minimum standard of service (reference level) for a single property is a flow of 9l/min at a pressure of 10m head on the customer's side of the (Southern Water) main stop tap/meter.
3.6	Design Guidance - Services	
3.6.1	Service Design	
3.6.1.8		a) Unless otherwise agreed, each service pipe shall be designed and installed so as to be connected perpendicular on plan to the water main to which it is connected. b) Continuous lengths of pipe pipe shall be used and joints kept to a minimum.
3.6.4.4	Multiple Service Connections	a) Where multiple services are laid in a common excavation the Developer/SLO shall ensure that the following: <ul style="list-style-type: none"> ▪ Tappings of the main shall be located at a minimum spacing of 250mm apart ▪ Service pipes and service ducts shall be laid side by side with no inter-twining such that the first tapping serves the first property, the second property and so on, and the line of the ferrule and stopcock/meter correspond.
3.6.5	Meter Boxes (and meters)	
3.6.6.1		a) Southern Water's current standard policy for new properties is to install a combined meter/stopcock box and meter at the property boundary. b) At the time of writing Southern Water is installing wall mounted meter boxes as the preferred option for new property connections in Hampshire as part of a county-wide trail. Where wall mounted meter boxes are installed the service pipe between the water main and wall box shall be laid in a continuous length. Wall mounted meter box installations shall be designed and installed in accordance with the manufacturer's instructions and Southern Water's published terms and conditions. c) Southern Water have three options for metering new flats and multi occupancy premises:

		<ul style="list-style-type: none"> ▪ A bulk meter ▪ Individual meters in manifold pits ▪ Individual meters in meter cupboards (in accordance with Southern Water's published terms and conditions). <p>d) For individual meters, Southern Water will issue an individual NCF (New Connection Form) with every meter. When installing each meter, the Developer/SLO shall detach the bar code from the meter and attach it to the NCF, provide details of the initial reading on the NCF, the date of installation and location of the meter box. The completed NCF must be returned to Southern Water's site representative within one week of the meter installation.</p>
3.7	Construction	
3.7.1	General	See 1.6.7 and 1.6.8 above

**Appendix A
Southern Water Questionnaire Form SL2**

**SOUTHERN WATER
SELF LAY ORGANISATION SCHEME SPECIFIC DETAILS SL2**

**Self-lay Water Mains and Services
Questionnaire**

FORM SL2

Note: This form is for completion by the Self-Lay Organisation (SLO) on behalf of itself and its Contractor in relation to the named development stated below, and is to be signed by both the SLO and Contractor. If the SLO proposes to use only directly employed staff this should be indicated on the form.

1. Development Details

Name of Developer:
Site Name:
Site Address:

2. SLO Details

Name of Site Manager:
Name:
Tel No:
Mob No:
Fax No:
e-mail:
Name of Site Supervisor:
Tel No:
Mob No:
Fax No:
Address:
e-mail:

Will you employ a permanent Supervisor (other than the Contractors Supervisor) on site/ how often will your Supervisor attend the site:
Proposed number of mainlining operatives to be used on the site:
Proposed number of service laying operatives to be used on the site:

3. Contractor Details

Name:

Name of Site Manager:

Tel No:

Mob No:

Fax No:

e-mail:

Name of Site Supervisor:

Tel No:

Mob No:

Fax No:

Address:

e-mail:

Will you employ a permanent Supervisor on site / how often will your Supervisor attend the site:

Proposed number of mainlining operatives to be used on the site:

Proposed number of service laying operatives to be used on the site:

4. Summary of Training and Experience

Where persons to be employed on site are in possession of an EU Skills NCO (W) registration card, please attach a photocopy of this for our records. For people who do not hold an EU Skills NCO (W) registration card, Southern Water must be provided with evidence of appropriate qualifications for mainlaying / servicelaying. Please attach a schedule of training/ qualifications, experience and job descriptions/roles in respect of all such staff (this applies to both SLO and Contractors staff). Please also attach copies of certificates etc.

5. Health Screening

Each person to be engaged in the process of laying water mains or services must be in possession of an EU Skills NCO / National Water Hygiene card. Please attach a photocopy of each person's card for our records.

6. Approval of Fittings and Materials (Products and Substances)

Please provide/attach details in accordance with the Code of Practice for the Self-Laying of Water Mains and Services – England and Wales, (Part 3 – Civil Engineering Specification) and Southern Water's Company Specific Addendum to that document. Southern Water's SL3 form is available for this purpose.

7. Contractors Declaration (To be completed by a senior member of staff)

I certify that the information supplied is correct in all respects to the best of my knowledge.

Name:

Position:

Signature:

Date:

8. SLO's Declaration (To be completed by a senior member of staff)

I certify that the information supplied is correct in all respects to the best of my knowledge and that Southern Water will be supplied in writing with any changes to detail as they occur.

Name:

Position:

Signature:

Date:

Appendix B Hygiene Code of Practice

SOUTHERN WATER HYGIENE CODE OF PRACTICE

1. INTRODUCTION

The principal purpose of the Hygiene Code is to prevent contamination of potable water supplies. Whilst the Hygiene Code emphasises the need for special precautions in relation to certain defined “**restricted operations**”, these precautions must be supported by a high general standard of hygiene throughout all operations.

2. RESPONSIBILITY & APPLICATION

2.1 Every employee (including contractors and casual labour) must comply with the Hygiene Code,

2.2 Every SLO is responsible for ensuring compliance with the standards set by this Hygiene Code, including:

- Ensuring that employees (including Contractors, and casual labour) and visitors comply with the Hygiene Code.
- Ensuring that materials, equipment, plant, vehicles, buildings and other works comply, and are maintained in a condition consistent with this Hygiene Code.

3. TRAINING AND AUDITS

3.1. SLO's are responsible for ensuring that staff and contractors under their control receive appropriate training in the requirements of this code and that training records are maintained and updated accordingly.

3.2 By 31 December 2006, Southern Water will expect all site operatives employed on Self-Lay Water mains and services work, to hold a Water Hygiene card issued by Energy & Utility Skills.

3.3 In addition to formal training, SLO's shall ensure that informal training is provided (and recorded) at appropriate intervals as necessary to ensure standards are maintained.

3.4 In the absence of a Water Hygiene card issued by Energy & Utility Skills, Southern Water will hold evidence of formal training records in respect of site operatives.

3.5 Random audit checks will be carried out by Southern Water to ensure that appropriate training is being applied throughout the business.

4. INFRINGEMENTS

Infringements of the Hygiene Code will be reported to the Water Industry registration scheme (WIRS) if the SLO is accredited. In the case of an SLO who is not WIRS accredited, Southern Water will re consider their suitability to carry out Self-Lay water mains and services work.

5. DEFINITIONS

Throughout this document the following definitions apply:

5.1 “**clean**” means a normal standard of domestic cleanliness, free from faecal matter, dirt or any other contaminating substance.

5.2 “**contamination**” is defined as the introduction of any substance to drinking water that results, or may result in the water becoming unwholesome or unfit for human consumption, as defined in the Water Supply (Water Quality) Regulations 2000.

5.3 “**clean-water**” means all water resource, supply or distribution operations including the maintenance of associated equipment.

5.4 “**waste-water**” means all sewage, sewage treatment, sewage sludge, and sewerage operations including the maintenance of associated equipment.

5.5 “**multifunctional personnel**” means personnel approved for work on both Clean-water and Wastewater Operations.

5.6 “**multifunctional operations**” means work on both Clean-water and Wastewater Operations (including **Restricted operations** where appropriate).

5.7 “**restricted operations**” means work which may involve direct contact with untreated sources of underground water, with partially or fully treated water within water treatment works, or with treated water at any stage in its distribution.

Areas of **restricted operations** and activities are further defined as:-

- Surface water treatment works after final disinfection.
- Clear water tanks and break pressure tanks.
- Service reservoirs.
- Underground water treatment works including springs wells and borehole head chambers.
- The installation, repair, relining or renewal of mains, service pipes and fittings.
- The installation, repair and maintenance of associated equipment that is in contact with drinking water, e.g. meters.

6. MEDICAL

6.1 Before being approved to work on water mains and/or services, all personnel who have not been issued with a Water Hygiene card by Energy & Utility Skills, are required to:

- Complete a medical questionnaire prior to carrying out any work on site.

7. VISITORS TO SELF-LAY INSTALLATIONS

Visitors to Self-Lay installations (including delivery vehicle drivers, school parties etc) will not normally be required to satisfy the conditions outlined in section 6 above. A responsible SLO representative must ensure that such persons do not enter areas of **restricted operations** or in any way threaten water supply.

8. PERSONAL HYGIENE

8.1 Everyone working on wastewater and clean-water installations must pay the strictest attention to personal hygiene.

8.2 SLO's shall ensure adequate provision of toilet and cleansing facilities at places of work and in vehicles as appropriate to enable all personnel involved in clean-water operations to maintain adequate standards of personal hygiene.

8.3 The nature of the facilities required shall be assessed having regard to operational needs including consideration of the following factors:

- The size of the site and the amount of maintainable equipment
- Numbers of personnel, and duration that they are likely to be on site
- Proximity to other sites with facilities
- Health & Safety requirements

8.4 SLO's (and their contractors) shall provide all relevant staff with disinfectant wipes.

8.5 In the case of portable or temporary arrangements, particular care shall be taken to ensure that all wastes are disposed of without risk to the water supplies or the environment.

9. MULTIFUNCTIONAL PERSONNEL

9.1 It is accepted that the need for multifunctional employees may be consistent with the efficient use of a workforce, however, movements of staff between clean and wastewater functions shall be avoided where practicable and feasible because of the potential risk of cross contamination.

9.2 Where multifunctional personnel are employed it is imperative that adequate measures are put in place to ensure that drinking water supplies are not put at risk of contamination. This is of particular importance where **restricted operations** are concerned.

9.3 Staff normally engaged in clean-water operations must not operate in other areas posing a risk to clean water, without adequate training and the SLO (or Contractor) having a good operational need.

9.4 Staff normally engaged in Wastewater installations shall not work on Cleanwater installations without appropriate training and the SLO (or Contractor) having a good operational need.

9.5 Southern Water will maintain a register of all personnel approved for work on multifunctional operations:

9.6 Any employees who move from wastewater operations to clean-water operations as part of their working pattern must first:-

- Change their protective clothing to comply with Section 10 below.
- Wash their hands, and ensure clothing and footwear are clean and free from contaminating matter.
- Change or disinfect tools, plant and portable equipment in accordance

with Section 11.

- Maintain and operate their vehicles in accordance with Section 12.

10. CLOTHING

10.1 Protective clothing (overalls, footwear, gloves, waterproofs etc) used for clean-water operations shall not be used for wastewater operations (or vice versa).

10.2 Particular attention must be paid to protective clothing worn by personnel working on **restricted operations**. As far as practicable, such clothing shall be:

- Kept clean and free from contamination and stored away from other protective/waterproof clothing (trench workers and similar are not expected to meet the normal definition of clean in section 5 above).
- Used only for clean-water operations.

10.3 For all employees involved (even temporarily) in multifunctional operations:

- Two complete sets of protective clothing shall be provided, and shall be stored and used in accordance with 10.1 & 10.2 above.
- Clothing for use on **restricted operations** shall be clearly identifiable from clothing used for other purposes by means of suitable, securely fixed tabs and labels stating "CLEAN WATER OPERATIONS USE ONLY".
- Appropriate separate clean-water and wastewater dedicated kit bags shall be provided and shall be clearly identified as which function they apply.

10.4 Overalls that become heavily soiled must be changed before leaving the site.

10.5 Additional precautions (e.g. disposable overalls) may be required for certain **restricted operations** - refer to Southern Water for more details.

11. MATERIALS, TOOLS, SMALL PLANT AND EQUIPMENT

11.1 All materials, tools, small plant and equipment used in contact with water during **restricted operations** shall be inspected for cleanliness/cleaned and disinfected before use, installation or replacement as advised by Southern Water.

11.2 Wherever practical, items previously used in wastewater operations shall not be used on clean-water operations (including **restricted operations**). If wastewater items are to be used, particular care must be taken to ensure that they are thoroughly cleaned and disinfected before use.

11.3 Portable equipment used to convey treated water for **restricted operations** (e.g. pump sets, drinking water bowsers / tankers, standpipes and hoses etc, shall be:

- Used only for this purpose.
- Clearly identified via suitable, securely fixed, tags or labels stating the intended purpose – e.g. "FOR DRINKING WATER USE ONLY".

11.4 No item of fixed plant shall be transferred from a wastewater to a clean-water installation.

11.5 Clean-water items that are not returned clean and uncontaminated must be steam cleaned and disinfected before being stored.

11.6 New materials and equipment may be kept in a common store but shall be kept in segregated areas in accordance with Drinking Water Inspectorate Regulation 31.

11.7 All stores must be kept in a clean condition.

12. VEHICLES AND MOBILE PLANT

12.1 As far as practicable and feasible, vehicles and mobile plant used directly in support of Clean-water Operations shall not be used for other duties.

12.2 Before being admitted to any area of **restricted operations**, all items of mobile plant and vehicles (including specialist vehicles) must be in a clean condition.

12.3 Where such items of mobile plant and vehicles have previously been in use in wastewater operations where faecal contamination may have occurred, all affected parts of the equipment must, in addition to 12.1, be steam cleaned and thoroughly disinfected.

12.4 Under no circumstances shall items previously used to convey wastewater, be used to convey water for Clean-water operations (also see section 11 above with regard to tankers / bowsers).

12.5 Vehicles and mobile plant used in clean-water activities other than **restricted operations** must also be maintained in a clean condition.

12.6 Specialist vehicles (e.g. tractor units) may be used for haulage of both sewage and potable water tankers, but must be kept in a clean condition.

12.7 Under no circumstances shall vehicles be used to transport clean-water materials and equipment for use in **restricted operations** in the same compartment at the same time as waste-water items.

12.8 Vehicles or vehicle compartments which have previously transported waste water items must be thoroughly cleaned and disinfected before use for transporting items intended for use in clean-water operations and particularly **restricted operations**.

13. TRANSPORTATION OF ANIMALS

No animals

Appendix C

Disinfection Code of Practice

SOUTHERN WATER

DISINFECTION & HYGIENE PROCEDURES FOR NEW WATER MAINS AND SERVICES

1. INTRODUCTION

The installation of new water mains and services represents a potential opportunity for contamination to enter the distribution system. The following procedures detail the precautions to be taken during such work to minimise the risk of contamination occurring. The procedures are based on the Water UK industry best

practice document: Principles of Water Supply Hygiene and Technical Guidance Notes.

2. SCOPE

These procedures apply to the installation of water mains and services for the provision of water supplies suitable for domestic purposes. For the purposes of these procedures a "main" is defined as any pipe of 50mm internal diameter (typically 63mm outside diameter) or greater. Service pipes will not normally require disinfection unless the internal diameter exceeds 50mm and the length exceeds 15m, or there are doubts over the cleanliness of the pipework. Where new linings are drawn into existing mains, these shall be treated generally as new mains.

3. RESPONSIBILITY

- Head of Water Quality SWS.
- Water Managers & Managers SWS.
- All persons involved in the works described within these procedures, including contractors.

4. GENERAL

No person shall be permitted to carry out these works until they have:

- Completed a Southern Water health questionnaire and had this approved by the relevant Southern Water Manager.
- Received appropriate training.

Only materials and substances that are approved under Regulations 31 of the Water Supply (Water Quality) Regulations 2000 and appear in the current list published by the DWI shall be used. Pipes and fittings shall be stored, transported, and installed in ways which minimise the risk of contamination occurring:

- Pipes and fittings shall be stored avoiding ground contact (i.e. on pallets and plastic sheeting).
- Pipes shall be capped during storage and, as far as practicable, during installation to avoid the ingress of ground/trench water and animals' etc. This is of particular importance during breaks in the installation process and where the site is left unattended.
- Appropriate trench drainage measures (pumps etc) shall be installed to avoid the ingress of trench/ground water into new or existing mains. Particular care must be taken when carrying out connections to the in-service mains network (see section 8 below).

5. TEMPORARY WATER SUPPLIES / FINAL CONNECTION

Only mains drinking water supplies shall be used for testing, flushing, swabbing and disinfection operations. Pipe-work configurations between new and existing mains for the purposes of providing temporary water supplies for testing, flushing, swabbing, and disinfection operations and for subsequent final connections, shall be installed in ways that safeguard the existing in-service mains and services from potential contamination. The actual method of connection will vary according to the nature of the works and specific approval for the method to be used must be sought from the relevant Southern Water Manager. The following outline methods are approved for use:

(a) Spade & By-pass Arrangement

A "spade" (i.e. blanking plate) is installed at the point of connection (i.e. closed valve) between the new and in-service mains, and a temporary by-pass incorporating a double check valve assembly is installed around this point to provide the temporary water supply. The spade is left in place until after a satisfactory sample result has been obtained.

(b) Rider Pipe Arrangement

A temporary rider pipe incorporating a double check valve assembly is installed between the two mains, with the new and existing mains being otherwise left physically disconnected until after a satisfactory sample result has been obtained.

Notes:

1. Method a) above shall be used as far as practicable in order to avoid the need to fully drain down and open new or existing mains to carry out final connections (see section 8 below).
2. For both of the above methods the temporary supplies shall be isolated and disconnected when not in use. This is of particular importance where the site is left unattended and during the disinfection contact period.
3. For smaller diameter mains by-pass/rider main connections will be generally be connected via ferrules, and for larger mains via standpipes and hydrants.
4. See detail drawings of typical bypass arrangements, contained in Fig 8 and Fig 9 within appendix 'C' to this addendum.

6. PROVISION OF SAMPLING QUESTIONNAIRE FORM SL3 POINTS

Sufficient sampling points shall be provided at suitable points to enable representative water samples to be taken of the complete length of new mains installed. The precise numbers and location of sampling points shall be agreed with the relevant Southern Water Manager or representative in accordance with the following guidelines:

- (a) For relatively short sections of main the use of permanent or temporary end hydrants will generally be sufficient for this purpose.
- (b) For longer sections of main interim sampling points shall be required at intervals of not greater than 500m.

7. NEW MAINS DISINFECTION

New mains shall be disinfected in accordance with this section. Disinfection shall be carried out post swabbing, flushing and pressure testing operations. The main shall be swabbed and flushed through its entire length until the supply runs consistently clear. Only new, clean swabs shall be used. Care shall be taken to ensure that the wash water does not re-enter the main after the swabs have come out. All swabs must be recovered and accounted for and the retrieval point must be immediately resealed. Fittings and connection points should be inspected for cleanliness and sprayed with a 1000 mg/l free chlorine solution immediately prior to installation. The new main shall be charged with water containing a 20mg/l free chlorine concentration for a minimum contact period of 16 hours in accordance with the following procedure:

- (a) Accurate control of the chlorine concentration and even distribution of the chlorinated water shall be achieved by introducing hypo-chlorite into the main at a controlled rate via suitable dosing equipment and measured flushing flows. The chlorine concentration shall be checked using a comparator at each downstream hydrant whilst the water is being discharged.

(b) De-chlorination shall be carried out wherever the discharge water presents a risk to the environment or as otherwise specified by the Southern Water Manager or Environment Agency.

(c) When the chlorinated water has been discharged for sufficient time to achieve a 20mg/l free chlorine concentration at all outlets, the main shall be shut down and left to stand for a minimum disinfection contact period of 16 hours.

(d) At the end of the disinfection contact period the residual chlorine concentrations shall be re-checked.

(e) Where free chlorine concentrations have dropped to below 15mg/l this indicates that contamination may be present within the main. In this event the cause shall be investigated and the main re-flushed, swabbed and chlorinated as appropriate.

(f) When satisfactory results have been obtained the main shall be flushed/dechlorinated until normal background chlorine levels are achieved. The main shall then be left to stand for a further 24 hours prior to sampling.

8. SAMPLING & FINAL CONNECTION/COMMISSIONING

New mains shall not be connected to existing in-service mains and brought into service (commissioned) until the necessary water sample passes have been obtained and confirmed in writing. Following cleaning and disinfection, Southern Water (or Southern Water approved sampling contractor) shall take representative water samples from the new main. As a minimum each water sample shall be analysed for residual chlorine, coliforms and turbidity and checked for qualitative odour and appearance using the acceptance criteria detailed below:

Determine and Acceptance Criteria

Total Chlorine 0.1-0.4 mg/l

Free Chlorine 0.1-0.4 mg/l

Total Coliforms 0/100 ml

Faecal Coliforms 0/100 ml

Turbidity <1 FTU

Qualitative Odour Nature = 1 Intensity = 0

Appearance Presence = 0 Absence = 1

Where the final connection involves depressurisation and draining down of the existing in-service main and opening/exposing the main to possible contamination the following shall apply:

1. Where the site is known or suspected to be contaminated prior to commencement of the works, the Pipelayers shall ensure that additional trench drainage, health and safety and customer protection measures are put in place, as appropriate.

2. Southern Water's Distribution Inspector will, wherever practicable, avoid fully closing the main prior to excavation by partially restricting the appropriate controlling valve(s) in order to maintain a minimal positive water pressure at the site of the works.

3. The Pipelayers shall excavate to a sufficient depth below the invert of the main and install sufficient pumps to ensure adequate protection against rising trench water ingress into the main and adequate working room for the installation/replacement of fittings. Particular care shall be taken once the open ends of the main have been exposed.

4. The Distribution Inspector will then fully close down the controlling valve(s) as required in order for the works to progress.
5. The Pipelayers shall ensure that tools, new fittings and the existing mains and fittings in the vicinity of the works are clean and free from debris.
6. The Pipelayers shall ensure disinfection of the works as follows:
7. All tools, new fittings and the existing mains and fittings in the vicinity of the works shall be kept clean and free from debris.
8. "Chemtab" chlorine release tablets, as approved for use under Regulation 31 of the Water Supply (Water Quality) Regulations shall be used.
9. The disinfection solution shall be prepared by diluting 1 "Chemtab" tablet in a hand lever operated spray container containing 1 litre of drinking water, to give an available chlorine content of 1000mg/l.
10. The disinfection solution shall be retained for use for a maximum of 24 hours, after which any remaining solution shall be discarded after dilution with a further 10 parts of water and shall be discharged in a manner that does not present a risk to the environment.

- a) The "Chemtab" tablets and the associated spray bottles of disinfection solution shall be stored within the vehicle, in cool dry conditions, away from direct sunlight.
- b) Immediately prior to the installation of fittings, the disinfection solution shall be applied by spraying in a steady stream rather than a mist, to ensure complete coverage of new/replacement fittings and, where practicable subject to any remaining positive water pressure, the existing main local to the works. In addition to the above, the pipelayers shall, by similar methods, disinfect the exposed internal and external surfaces of the existing main and fittings. Every effort shall be made to exclude dirty water ingress / mains contamination during the course of works, as described in 1-10 above, however, where despite precautions, a quantity of dirty water/contamination does enter the new or existing mains whilst carrying out the final connection, the following shall apply:

1. The Pipelayers shall take immediate action to prevent further ingress and shall inform Southern Water's Distribution Inspector.
2. Southern Water's Distribution Inspector, in liaison with the Pipelayers, shall assess the seriousness of the incident and the additional actions required in accordance with the guidelines detailed below.

(a) Minor Soiling At Mains Opening(s)

This is where there is only minor soiling at the mains opening and where there is no evidence of potentially hazardous contaminants within the trench and associated trench water from which the soiling has occurred (see (c) below for a definition of hazardous contaminants). Southern Water's Distribution inspector will ensure that the main is flushed thoroughly before returning to service, then obtain water samples in all instances.

(b) Ingress From Mains Water In Trench After Drain Down

This is where mains water from within the trench rises to submerge and enter the mains opening(s) after completion of the initial mains isolation, cutting (where necessary) and drain down operations. This carries the same level of risk as the presence of mud/silt in the main (other than normal mains deposits), which should be acknowledged as an indication that a quantity of dirty water has entered the main. The two scenarios detailed above, only apply where there is no evidence of the presence of hazardous contaminants (see (c) below for a definition of hazardous contaminants).

Southern Water's Distribution Inspector will flush the main thoroughly, however, the SLO/Contractor shall ensure that prior to Southern Water sampling and returning the

main to service, the following enhanced disinfection (chlorination) procedure is carried out under Southern Water's supervision:

- Enhanced disinfection shall be achieved by flushing and charging the main with water containing a free chlorine content of 50mg/l for a minimum contact time of 30 minutes.
- Particular care shall be taken to ensure that all of the affected sections of main are adequately disinfected and that customers do not receive contaminated or heavily chlorinated water prior to or during the chlorination process.

- The affected section(s) of main shall be kept fully isolated except where upstream pressure is required during the chlorination / flushing process.
- Individual customer connections shall be fully isolated by closing company stopvalves and where necessary and practical, customer stopvalves. Prior to chlorination, Southern Water will deliver customer information cards to every property, these will include a warning not to attempt to draw water until further notice.
- Alternative supplies shall be provided as appropriate.
- Safe working practices shall be employed at all times.
- Only Hypochlorite Solutions approved for use under Regulation 31 of the Water Supply (Water Quality Regulations) shall be used.
- Where necessary, chlorination points shall be installed at the upstream valve(s) to ensure complete disinfection.
- Wherever practicable existing hydrants shall be used to create chlorination flushing flows but where suitable existing hydrants are not available additional flushing points shall be installed to ensure even distribution of the chlorinated water and complete flushing prior to returning the main to service.
- Accurate control of the chlorine strength and even distribution of the chlorinated water shall be achieved by introducing hypochlorite solution into the main at a controlled dosing rate via purpose designed chlorination equipment and measured flushing flow(s).
- Care shall be taken to ensure that the heavily chlorinated water cannot backflow or backsiphon into the feeder main.
- In all cases the flushing flows / upstream pressure shall be monitored constantly during the chlorination process. Where a significant drop in flow / pressure is detected the upstream feeder main and chlorination equipment shall be immediately isolated to prevent the possibility of backflow /backsiphonage occurring. This is of particular importance where direct injection is used.

- For fully automatic flow proportional dosing (e.g. hydrant to hydrant) a double check valve assembly shall be incorporated within the inlet pipework (e.g. standpipe) feeding the chlorination unit.
- Where direct injection is carried out care shall be taken to ensure excessive quantities of undiluted hypochlorite cannot build up at the point of injection.
- Only the appropriate small diameter direct inject lines shall be used.
- Direct injection lines shall only be connected directly to the Through-flow of mains being chlorinated and not via offset communication pipes or hydrant legs.
- In order to confirm correct chlorine strength and coverage, flushing flow(s) shall be tested during the chlorination process using a suitable chlorine meter or comparator until free chlorine residuals of 50mg/l are achieved.
- The main shall then be fully isolated and left to stand for a minimum contact period of 30 minutes.
- For heavily contaminated mains an extended contact period of up to 2 hours may be required.
- At the end of the contact period further chlorine residual tests shall be carried out. Where residuals have decreased to a level of 35 mg/l or less, the need for further disinfection shall be considered.

- On completion of disinfection the main shall be flushed thoroughly and then tested until maximum free chlorine residuals of 0.4 mg/l, or an appropriate (lesser) local level is achieved at all outlets.
- De-chlorination shall be carried out wherever there is risk contaminating the environment, for example by way of drains sewers or watercourses.
- Water Samples shall be taken from every section of main Affected by the contamination incident.
- On restoring supplies, Southern Water will deliver further customer information cards.

(c) Hazardous Contamination Incidents

This is where a potentially hazardous contaminant is identified or Suspected within the trench or associated trench water from which the dirty water ingress/contamination has occurred. Some examples of hazardous contaminants are:

- Water from any drain or sewer
- Commercial waste or chemicals
- Fuel oils
- Farmyard slurry
- Ditch, river or pond water

The actions detailed in (b) above shall be carried out and in addition, Southern Water's Distribution Inspector and the Pipelayers shall ensure that the main and customer service connections are fully isolated as a matter of urgency. The main shall not be returned to service until clearance is obtained from Southern Water following confirmation of the necessary bacteriological sample passes: Mains shall not be sampled, connected and commissioned unless (within 7 days of commissioning) there will be sufficient turnover of water within the new main (i.e. from connections/draw offs) to ensure water quality is maintained. Mains shall be connected and commissioned as soon as possible following confirmation of the relevant sample passes. At the time of commissioning, mains shall be flushed to ensure a complete change of water. If not connected and commissioned within 7 days of the relevant sample pass(es) having been confirmed, mains shall be flushed within this period to ensure a complete change of water. Further flushing shall be carried out within every subsequent 7-day period prior to commissioning, and at the time of commissioning.

Where mains are left standing/un-flushed for a period of more than 7 days following the relevant sample pass(es) having been confirmed, they shall, in addition be resampled prior to commissioning. The need for further disinfection shall also be considered.

9. SERVICE PIPES

All new services shall be inspected for cleanliness, and flushed with mains drinking water immediately prior to being used for supply. If there is any doubt over the cleanliness of the pipe-work this shall be either replaced or disinfected and sampled generally as for new mains. Service pipes shall not be connected to mains until the mains have been sampled and commissioned in accordance with section 8 above.

10. RELATED DOCUMENTS

Principles of Water Supply Hygiene & Technical Guidance Notes (Water UK).
Southern Water's Hygiene Code of Practice (appendix 'B' to this addendum).
Typical Detail Drawings Fig 8-9 (appendix 'D' to this addendum).

Appendix D
Typical Details of Temporary Spade & Bypass Arrangements
SOUTHERN WATER
TYPICAL DETAILS OF TEMPORARY SPADE & BYPASS
ARRANGEMENTS FIG 8 & FIG 9

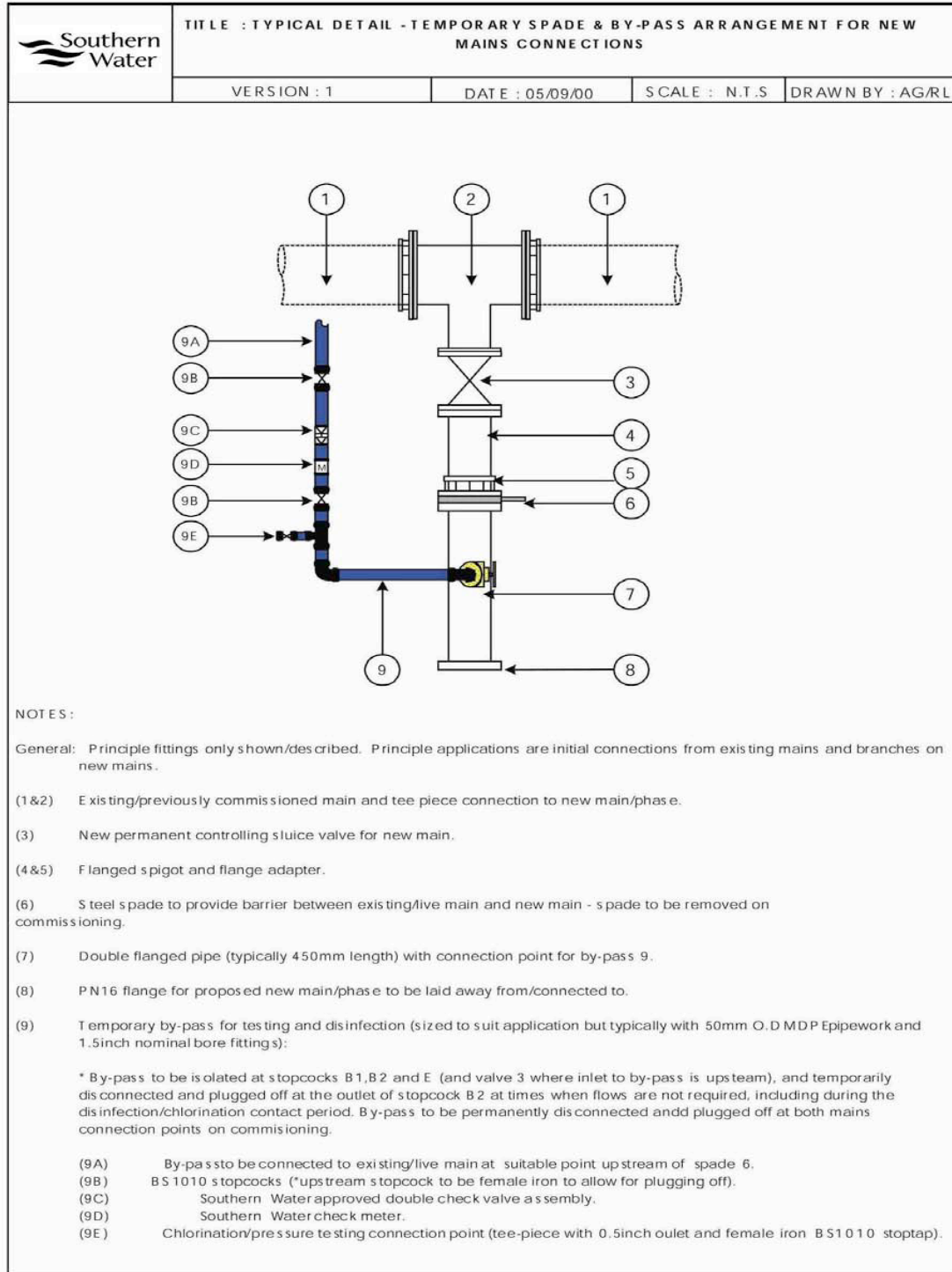

Fig 8: TEMPORARY SPADE AND BY-PASS ARRANGEMENT

FOR A NEW WATER MAINS CONNECTION

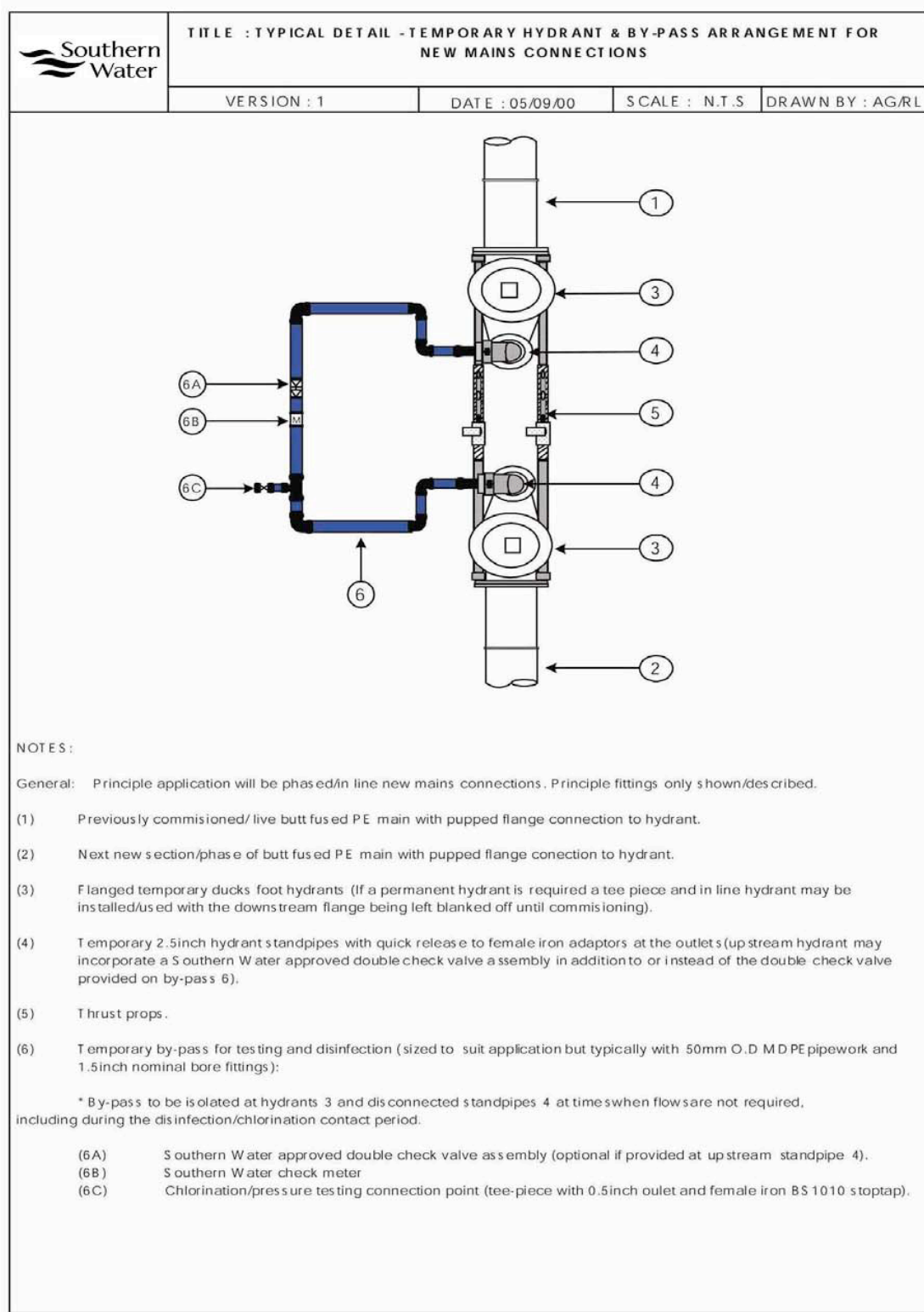

Fig 9: TEMPORARY HYDRANT AND BY-PASS ARRANGEMENT FOR A NEW WATER MAINS CONNECTION

Appendix E
Schedule of Southern Water Charges

SOUTHERN WATER
CHARGES FOR NON-CONTESTABLE WORK AND ADDITIONAL ITEMS

- Water main layout designed or checked by Southern Water for on-site water mains including capacity check.

No. of Units	Cost £
0-50	£1,254.00
51-250	£1,741.20
251-500	£1,984.80
>500	£2,228.40

- Checking and approval of materials to be procured independently by the SLO/Contractor (per application) = £116.80
- Administration charge per meter for domestic meter installation by Contractor/SLO - £48.69 (Zero Rated for VAT)
- Administration charge per meter for domestic meter installation by Southern Water - £90.69 (Zero Rated for VAT)
- Connection of new main to existing distribution network to include water sampling and quality testing is estimated on a job by job basis.
- Southern Water's Supervision fee will be charge at £67.00 per hour
- Preparation and completion of agreement - £363.65 (per agreement)
- Pre-qualification check of SLO and medical clearance check - £262.80 (per application)
- Water Distribution (hydraulic) capacity check.

No. of Units	Cost £
0-50	£243.60
51-250	£730.80
251-500	£974.40
>500	£1,218.00

- Pressure testing of new mains = estimated on a job by job basis
- Disinfection = estimated on a job by job basis

Note: Except where stated, all charges include 20% VAT.
All charges correct at date of publication.

**Appendix F
QUESTIONNAIRE FORM SL3**

**SOUTHERN WATER
QUESTIONNAIRE FORM SL3
MATERIALS IN CONTACT WITH POTABLE WATER**

All materials, without exception, which come into contact with potable water in the project named below, must be listed on this form.

Project Title

SLO

Contractor

Product or Process	Supplier Other	Information (Including Ref. No.)
--------------------	----------------	----------------------------------

FOR OFFICIAL USE ONLY

Date sent to Water Quality Manager:

Signed by Water Quality Manager: _____ Date

This form must be kept for at least five years by Southern Water's Project Manager.

This form should be sent to the Water Quality Manager for signature, then returned to the Southern Water Project Manager.